

TM 11-5895-1047-10

Technical Manual

HEADQUARTERS

DEPARTMENT OF THE ARMY

30 June 1980

TM 11-5895-1047-10

Washington, D.C.

**OPERATOR'S MANUAL
PLATOON EARLY WARNING SYSTEMS
AN/TRS-2(V)1 (NSN 5895-01-063-8103)
AN/TRS-2(V)2 (NSN 5895-01-073-9032)
AN/TRS-2(V)3 (NSN 5895-01-063-8104)
AN/TRS-2(V)4 (NSN 5895-01-068-6748)
AN/TRS-2(V)5 (NSN 5895-01-068-6748)
AN/TRS-2(V)6 (NSN 5895-01-068-6749)**

REPORTING OF ERRORS

You can improve this manual by recommending improvements using DA Form 2028, (Recommended Changes to Publications and Blank Forms) and forward to the Commander, US Army Communications and Electronics Materiel Readiness Command, ATTN: DRSEL-ME-MQ, Fort Monmouth, New Jersey 07703.

In either case a reply will be furnished directly to you.

Change in Force C 2

TM 11-5895-1047-10
*C 2

CHANGE

No. 2

HEADQUARTERS
DEPARTMENT OF THE ARMY
WASHINGTON, DC, 12 September 1983

Operators Manual

PLATOON EARLY WARNING SYSTEMS

AN/TRS-2(V)1 (NSN 5895-01-063-8103)

AN/TRS-2(V)2 (NSN 5895-01-073-9032)

AN/TRS-2(V)3 (NSN 5895-01-063-8104)

AN/TRS-2(V)4 (NSN 5895-01-068-6747)

AN/TRS-2(V)5 (NSN 5895-01-068-6748)

AN/TRS-2(V)6 (NSN 5895-01-068-6749)

TM 11-5895-1047-10, 30 June 1980, is changed as follows:

Page i, "REPORTING OF ERRORS" is superseded as follows:

REPORTING ERRORS

AND RECOMMENDING IMPROVEMENTS

You can help improve this manual. If you find any mistakes or if you know of a way to improve the procedures, please let us know. Mail your letter or DA form 2028 (Recommended Changes to Publications and Blank Forms) direct to: Commander, US Army Communications-Electronics Command and Fort Monmouth, ATTN: DRSEL-ME-MP, Fort Monmouth, New Jersey 07703. We'll send you a reply.

Page 1-1, paragraph 1-3, line 7. Change "Commander, US Army Communications and Electronics

This Change supersedes Change1, 20 July 1981.

Material Readiness Command, ATTN: DRSEL-ME-MQ, Fort Monmouth, New Jersey 07703"to "Commander, US Army Communications-Electronics Command and Fort Monmouth, ATTN: DRSEL-ME-MP, Fort Monmouth, New Jersey 07703. "-

Page 1-2, paragraph 1-5.1 is added after paragraph 1-5.

1-5.1. Hand Receipt

This manual has a companion document with a TM number followed by "-HR" (Hand Receipt). TM 11-5895-1047-10-HR consists of preprinted hand receipts (DA Form 2062) that list end item related equipment, i.e., (COEI, BII, and ML), which you must account for. As an aid to property accountability, additional -HR manuals maybe requisitioned from the US Army Adjutant General Publications Center, Baltimore, MD, in accordance with procedures in Chapter 3, AR 310-2 and DA PAM 310-10-2.

Page 1-3, Section H, Paragraph 1-66, is superseded as follows:

b) Capabilities

Remotely detects, locates, and classifies personnel or vehicles within 10 meters of the emplaced detector. Maximum range between detector and receiver is 1500 meters for RF line-of-sight or wire (WD-36).

Page 1-6, line 17. After " Ž BA-3090 batteries are used for low temperature operation" Add "; however, BA-3090 battery life may be reduced at temperatures below - 5°C. "

Page 2-6, paragraph 2-4. Subparagraph d is added after subparagraph c.

d. If your equipment fails to operate, troubleshoot, using the procedure in Chapter 3. Report any deficiencies, using the proper forms. See TM 38-750.

Page 2-9, paragraph 2-6 NOTE. Change "... in radio mode . . ." to ". . . in the RF mode ..."

Page 2-25, paragraph 2-8a(l). Under "Site Considerations" add "Z Emplace detectors at least 10 meters from metal objects that can cause false triggering of the detector, e.g., metal fences, barbed wire, metal stakes, etc. "

Page 2-26. Illustration is superseded by enclosed illustration.

Page 2-29, line 2. Change "Do not cover top of detector case. " to "Do not cover top of detector case with rocks or soil. To conceal the detector, use vegetation (grass, pine needles, etc.) found in vicinity. "

Page 2-29, line 10. After ". . . camouflage as necessary. " Add "Bury or stake field wire securely to the ground to prevent movement. Blowing or moving field wire may reduce detector performance or cause false alarms. "

Page 2-32. Change "CAUTION" to read:

CAUTION

Grounding rod should always be connected to the wire link during operation to prevent damage to the equipment caused by lightning striking or high voltage lines accidentally contacting the field wire input lines.

Page 2-43, Section IV, paragraph 2-11, subparagraph a, line 4. After". . . hard ground and icing conditions. " Add "if the ground is frozen, the detector may be deployed without holding stakes. Make sure the detector is firmly implanted."

FIG. 1

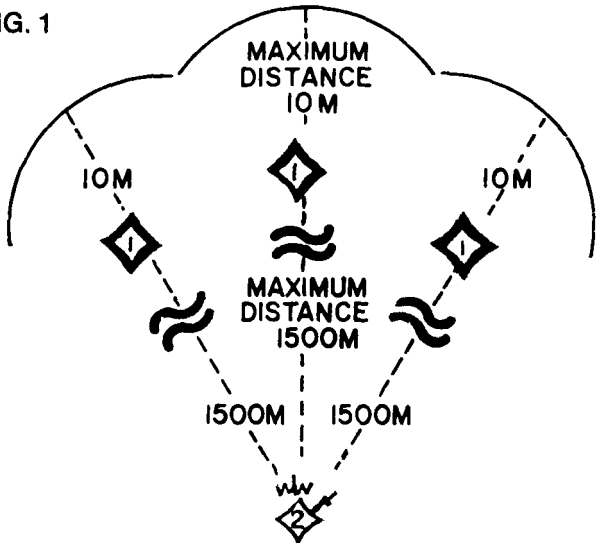

- 1 DETECTOR POSITION
- 2 RECEIVER POSITION

TYPICAL PEWS CAPABILITY

By Order of the Secretary of the Army:

Official:

JOHN A. WICKHAM JR.
General, United States Army
Chief of Staff

ROBERT M. JOYCE
Major General, United States Army
The Adjutant General

DISTRIBUTION:

To be distributed in accordance with DA Form 12-36B,
Operator/Crew Maintenance requirements for AN/TRs-2,

TM 11-5895-1047-10

	Differences in Equipment	1-8	1-10
	Technical Principles of Operation	1-9	1-10
CHAPTER 2.	OPERATING INSTRUCTIONS		2-1
Section 1.	DESCRIPTION AND USE OF OPERATOR'S CONTROLS AND INDICATORS		2-1
	Receiver R-1808(V)/TR-S-2(V) Controls and Indicators . .	2-1	2-1
	Detector DT-577(V)/TR-S-2(V) Controls and Indicators . .	2-2	2-3
	Wire Link MX-9738/TRS-2(V) Controls and Indicators	2-3	2-4
Section II.	PREVENTIVE MAINTENANCE CHECKS AND SERVICES		2-6
	General	2-4	2-6
	Routine Checks	2-5	2-6

TM 11-5895-1047-10

Section III.	OPERATION UNDER USUAL CONDITIONS.		2-9
	Assembly and Preparation for Use	2-6	2-9
	Initial/Premission Checks	2-7	2-16
	System Planning and Installation .	2-8	2-25
	Operating Pro- cedure	2-9	2-33
	Preparation for Movement	2-10	2-40
Section IV.	OPERATION UNDER UNUSUAL CON- DITIONS		2-43
	Operation in Unusual Weather	2-11	2-43
	Precautions to Follow	2-12	2-44
CHAPTER 3.	MAINTENANCE IN- STRUCTIONS . . .		3-1
	Lubrication In- structions	3-1	3-1
	Troubleshooting Procedures	3-2	3-1
	Cleaning	3-3	3-7

APPENDIX A.	REFERENCES	A-1
APPENDIX B.	COMPONENTS OF END ITEM AND BASIC ISSUE ITEMS LISTS . . .	B-1
APPENDIX C.	ADDITIONAL AUTHORIZA- TION LIST	C-1
APPENDIX D.	EXPENDABLE SUPPLIES AND MATERIALS LIST	D-1

TM 11-5895-1047-10

HOW TO USE THIS MANUAL

The variation number appears following the (V) in the equipment nomenclature. The variation number is used to identify the operating frequency of the Detectors and Receivers. All of the Detectors and Receivers, which operate on the same frequency, have the same variation number.

In this manual, when official nomenclature is used but operating frequency is not important, the variation number will not be used. For example, when you see AN/TRS-2(V) without a number following the (V), you will know that it means all variations and all frequencies.

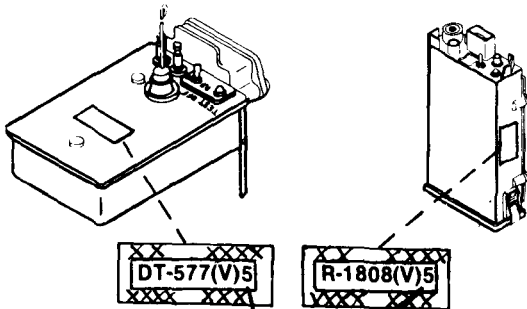

NOTE

The PEWS will not operate in radio mode unless receiver and detector variation number are the same.

CHAPTER 1 INTRODUCTION

Section 1. GENERAL INFORMATION

1-1. SCOPE.

This manual is for your use in operating Platoon Early Warning System (PEWS) AN/TRS-2(V). It gives detailed operating instructions, and will tell you how to set up and maintain the equipment.

1-2. MAINTENANCE FORMS AND RECORDS.

Department of the Army forms and procedures used for equipment maintenance will be those prescribed by TM 38-750, The Army Maintenance Management System (TAMMS).

1-3. REPORTING EQUIPMENT IMPROVEMENT RECOMMENDATIONS (EIR's).

If your PEWS needs improvement, let us know. Send us an EIR. You, the user, are the only one who can tell us what you don't like about your equipment. Let us know what you don't like about the design. Tell us why a procedure is hard to perform. Put it on an SF 368 (Quality Deficiency Report). Mail it to us at: Commander, US Army Communications and Electronics Materiel Readiness Command, ATTN: DRSEL-ME-MQ, Fort Monmouth, New Jersey 07703. We'll send you a reply.

TM 11-5895-1047-10

1-4. NOMENCLATURE CROSS REFERENCE LIST.

Common Name	Official Nomenclature
PEWS	Platoon Early Warning System AN/TRS-2(V)1 thru 6
Receiver	Receiver, Radio R-1808(V)/TRS-2(V)
Detector	Detector, Anti-Intrusion DT-577(V)/TRS-2(V)
Wire Link	Sensor Interface, Wire Link MX-97381TRS-2(V)
Headset	Headset
Grounding Rod	Grounding Rod
Bag	Case CY-7524/TRS-2(V)

1-5. LIST OF ABBREVIATIONS AND ACRONYMS.

Abbreviations are spelled out the first time they appear in the text. This list will help you familiarize yourself with terms used in the manual.

ANT	Antenna
DSPL	Display
GND	Ground
PEWS	Platoon Early Warning System
REC	Receive
RF	Radio Frequency
W	Wire Mode

Section II. EQUIPMENT DESCRIPTION

1-6. EQUIPMENT PURPOSE, CAPABILITIES, AND FEATURES

a) Purpose of PEWS

The Platoon Early Warning System is an early warning system for use by platoons, squads, or patrols.

b) Capabilities

Remotely detects, locates, and classifies personnel or vehicles to a maximum range of 1500 meters.

TM 11-5895-1047-10

c) Features

- Lightweight
- Weatherproof
- Battery operated
- Easily concealed
- Built in self-test circuits
- Reliable
- Remotely operated

d) Components (Two bags each containing)

- 1- Receiver
- 1- Adapter, Receiver Antenna
- 1- Receiver Antenna
- 5- Detectors
- 5- Detector Antennas
- 1- Grounding Rod
- 1- Wire Link
- 1- Headset
- 10- Detector Holding Stakes

e) Equipment Data

- Weights and Dimensions AN/TRS-2(V)
(System packed in 2 bags)

Each bag approximately:

Length	18 in.
Width	6.0 in.
Height	6.6 in.
Weight	11.0 lbs.

- . performance Data

Power Requirements

Receiver R-1808(V)/TRS-2(V) Two (2)
9 volt
BA-90/U or
BA-3090/U
Batteries

TM 11-5895-1047-10

Detector DT-577(V)/TRS-2(V)	One (1) 9 volt BA-90/U or BA-3090/U Battery
Wire Link MX-9738/TRS-2(V)	Powered by Receiver R-1808(V) /TRS-2(V)
Battery Life	

TEMPERATURE RANGE	BATTERY TYPE	RECEIVER	DETECTOR
Above 5°C (40°F)	BA-90	3 days	14 days
-5°to +5°C	BA-3090*	3 days	16 days

All batteries are 9VDC.

- BA-3090 batteries are used for low temperature operation.

● Operating Frequency

System Variation	Operating Frequency (Megahertz)
AN/TRS-2(V)1	139.100
AN/TRS-2(V)2	139.250
AN/TRS-2(V)3	141.100
AN/TRS-2(V)4	148.925
AN/TRS-2(V)5	149.600
AN/TRS-2(V)6	150.600

1-7. DESCRIPTION OF MAJOR COMPONENTS

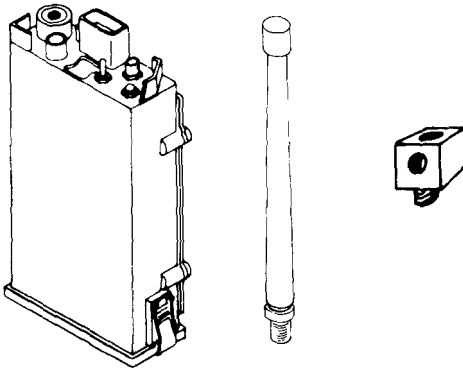

- 1 **RECEIVER.** (2 each) Battery-operated and weather proof. Receives radio signal or wire (using attached wire link) transmissions from detectors. Sends audible alarm signal to headset. Displays message in display window. Has self-test capability.
- 2 **ANTENNA.** (2 each) Screws into ANT socket on receiver. Used when operating in RF mode. Includes adapter so that antenna may be properly positioned.

TM 11-5895-1047-10

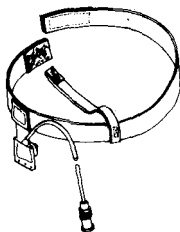

- 3 **HEADSET ASSEMBLY.** (2 each) Connects to PHONE connector on receiver. Sounds audible alarm when detector reports intruder.

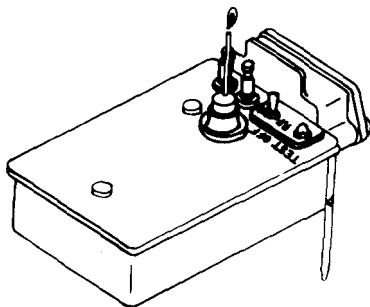

- 4 **DETECTOR.** (10 each) Small, light-weight, battery powered. Detects ground vibrations (personnel) or magnetic (vehicle) intrusions. Sends message to receiver by RF or wire transmission. Adapts to different environments, Has self-test features. Detector antenna screws into top of unit. Two ground holding stakes screw into bottom of each dSector.

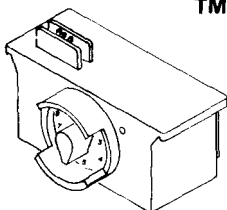

5 WIRE LINK. (2 each) Plugs into bottom of receiver when wire mode is used. Up to (9) pairs of wires from detectors may be connected to numbered terminal screws on bottom of wire module. Tests wires from detectors for open or short circuits.

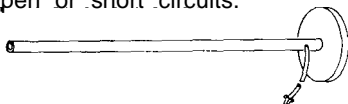

6 GROUNDING ROD. (2 each) Connects to terminal on bottom of wire link. Rod is pushed into ground to provide protection during wire mode operation.

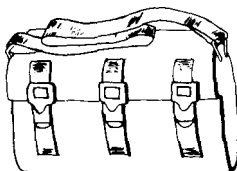

7 BAG. (2 each) Used to store and carry PEWS. Pockets inside bag protect components from damage or loss.

TM 11-5895-1047-10

1-8. DIFFERENCES IN EQUIPMENT.

The PEWS is available in six different operating frequencies. The variation number in the nomenclature is used to designate the operating frequency.

Detectors and receiver variation numbers must be the same.

1-9. TECHNICAL PRINCIPLES OF OPERATION.

SYSTEM

The AN/TRS-2(V) has two modes of operation, an RF mode and a wire mode. In the RF mode, detector DT-577(V)/TRS-2(V) detects the presence of an intruder and determines the type of intrusion (personnel or vehicle). The detector then transmits a coded signal to Receiver R-1808(V)/TRS-2(V). The signal is processed by the receiver which produces an audible tone, digital display or both, identifying the detector that is sensing an intrusion.

In the wire mode the detector is connected to the receiver via field wire using Wire Link MX-9738/TRS-2(V). The wire link provides for connection of up to nine detectors to a single receiver. Received signals are processed in the same manner as described for the RF mode.

CHAPTER 2
OPERATING INSTRUCTIONS

Section I. DESCRIPTION AND USE OF
OPERATOR'S CONTROLS AND
INDICATORS

2-1. RECEIVER R-1 808(V)/TRS-2(V) CONTROLS
AND INDICATORS

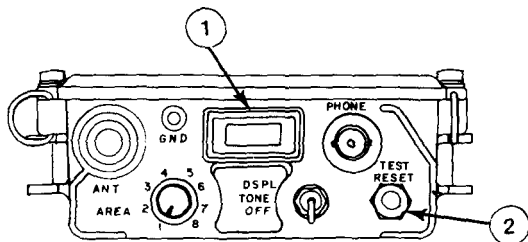

- ① **DISPLAY WINDOW** shows ID number of detector transmitting to receiver and type of intruder. First two digits are ID numbers (1 to 16), last digit is "P" (personnel intruder) or "C" (vehicle intruder).
- ② **TEST RESET** button allows you to test receiver battery and display. When pressed and held in, normal display is 8.8.8. If battery is Jew, display is 8 8 L or L. TEST RESET button also erases alarm messages from receiver memory and clears display when pressed momentarily.

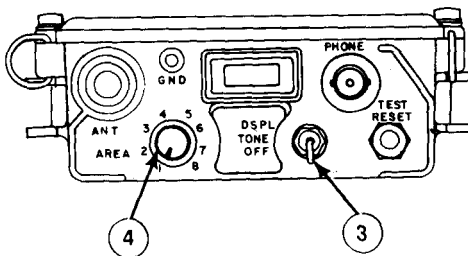

③ **DSPL-TONE-OFF switch**

Has three positions:

DSPL - Detector message is displayed and tone is heard in earphone when detector message is received. Detector messages stored in memory are displayed in sequence.

TONE - Display is turned off but tone is heard in earphone when detector message is received.

OFF - Shuts off receiver power.

④ **AREA** switch has eight (8) positions. Each group of detectors is assigned an area number. Set the AREA switch to the area number you are assigned to monitor.

2-2. DETECTOR DT-577(V)/TRS-2(V) CONTROLS AND INDICATORS

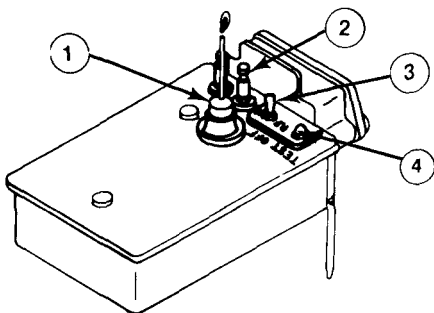

① **ANTENNA** post allows you to connect antenna to detector

② **DATA** terminal posts provide for connection of wire pair to wire link.

③ **RF-OFF-W** switch has three positions:

RF - selects the RF (radio) mode of operation (wireless)

OFF - turns off detector power

W - selects the wire mode of operation (wires must be connected to terminal posts)

④ **TEST** button provides for check of transmitter section.

TM 11-5895-1047-I0

2-3. WIRE LINK MX-9738/TRS-2(V) CONTROLS AND INDICATORS

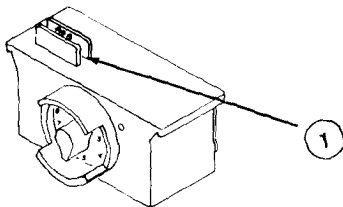

① **CONNECTOR** allows connection of receiver to wire link. Plugs into bottom of receiver.

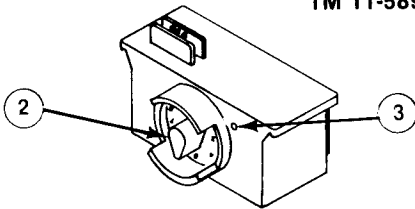

- ② **REC/TEST** switch has ten positions:

REC position is used during operation.
(Receive).

TEST positions 1-9 allow you to test field wire connections for open or short circuits.

- ③ **TEST IND** lights when **REC TEST** switch is turned to a wire link pair number.

STEADY light indicates that field wire is not broken or shorted.

BLINKING light indicates that wire is broken or shorted.

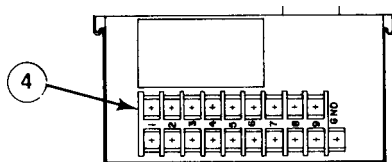

- ④ **WIRE TERMINALS 1 thru 9** are used to connect field wire pairs from wire link to the detectors. **GND** terminal is used to attach lead from ground rod to wire link.

**Section II. PREVENTIVE MAINTENANCE
CHECKS AND SERVICES**

2-4. GENERAL.

To be sure that equipment is always ready for your mission, you must do scheduled preventive maintenance checks and services. (PMCS).

PMCS TABLE

There are three categories of PMCS: B, D, and A. They are at the top of the INTERVAL column of the PMCS table. A check mark in one or more of the INTERVAL columns indicates the check and/or service that you should perform at a particular time.

- a. B means before. B-PMCS is performed BEFORE operation to make sure that the system is ready to work.
- b. D means during. D-PMCS is performed DURING operation.
- c. A means after. A-PMCS is performed AFTER operation.

2-5. ROUTINE CHECKS

Routine checks consist of cleaning and dusting checking for damaged equipment and missing parts. These are things you should do anytime you see they are required. Routine checks are not listed in the PMCS table.

PMCS TABLE

ITEM NO.	INTERVAL			ITEM TO BE INSPECTED	PROCEDURES CHECK FOR AND HAVE REPAIRED OR ADJUSTED AS NECESSARY	EQUIPMENT IS NOT READY/ AVAILABLE IF:
	B	D	A			
1		•	•	Receiver	<p>a. Check receiver area knob to see if it is loose.</p> <p>b. Check receiver battery compartment for worn or broken tether and wires.</p>	<p>Proper area can be located by using available tools (Tool Kit TE-33 field pliers). Generate a DA form 2404 to have the problem corrected.</p> <p>Bare wires could cause an electrical short.</p>
2			•	Detector	<p>a. Check detector battery compartment for worn or broken tether and wires.</p>	<p>Bare wires could cause an electrical short.</p>

TM 11-5895-1047-10

TM 11-5895-1047-10

NOTE

Use the ITEM NO. column in your PMCS table to get the numbers for the TM ITEM NO. column on DA Form 2404 (Equipment Inspection and Maintenance Worksheet) when you fill out the form.

EQUIPMENT INSPECTION AND MAINTENANCE WORKSHEET									
For use of this form, see TM 11-58-750; the component agency is the Office of the Deputy Chief of Staff for Logistics.									
1. ORGANIZATION 126 Signal Company, Fort Myer, VA					2. NOMENCLATURE AND MODEL Modem, DIGITAL DATA MD-1026 (1) (P) 6				
3. REGISTRATION/SERIAL/PSN	4a. MILES	4b. HOURS	4c. ROUNDS FIRED	4d. HOT STARTS	5. DATE 13 JAN 79	6. TYPE INSPECTION PMCS			
7. APPLICABLE REFERENCE									
TM NUMBER 11-5820-864-10		TM DATE OCT 79		TM NUMBER			TM DATE		
INSTRUCTIONS - Perform each check listed in the TM applicable to the inspection performed. Following the sequence listed in pertinent TM, complete form as follows:									
COLUMN a - Enter TM item number.					COLUMN d - Show corrective action for deficiency or shortcoming listed in Column c.				
COLUMN b - Enter the applicable condition status symbol.					COLUMN e - Individual ascertaining completed corrective action initial in this column.				
COLUMN c - Enter deficiencies and shortcomings.									
ALL INSPECTIONS AND EQUIPMENT CONDITIONS RECORDED ON THIS FORM HAVE BEEN DETERMINED IN ACCORDANCE WITH DIAGNOSTIC PROCEDURES AND STANDARDS IN THE TM CITED HEREON.									
8a. SIGNATURE (Person(s) performing inspection) <i>Joseph D. Kelly</i>			8b. TIME 0920 hours	8c. SIGNATURE (Maintenance Supervisor) L			8d. TIME	8e. MANHOURS REQUIRED	
TM ITEM NO.	STATUS	DEFICIENCIES AND SHORTCOMINGS			P	CORRECTIVE ACTION		INITIAL WHEN CORRECTED	
11		Power indicator lamp failed to light.				Replaced bulb.		J.D.L.	
S A M P									

DA FORM 2404
1 JAN 66

**Section III. OPERATION UNDER USUAL
CONDITIONS**

2-6. ASSEMBLY AND PREPARATION FOR USE

Check contents of carrying case against Components of End Item List (COEIL) to make sure the PEWS is complete. Check identification plates of receivers and detectors to be sure variation numbers are the same.

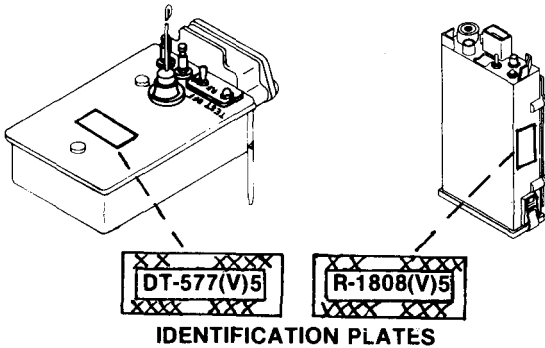

NOTE

The PEWS will not operate in radio mode unless receiver and detector variation number are the same.

TM 11-5895-1047-10

a) Receiver Preparation (RF MODE)

(1) Battery Installation

Receiver R-1808(V)/TRS-2(V) requires two batteries for operation. Batteries are installed as follows:

**BATTERIES
(BOTTOM)**

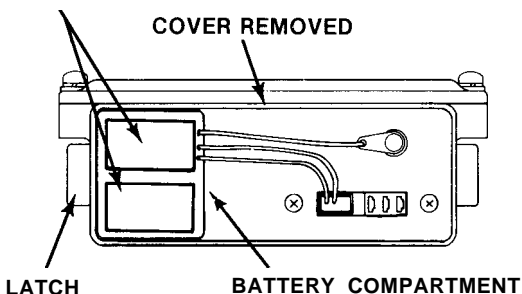

REAR VIEW

- Set DSPL-TONE-OFF Switch to OFF.
 - Release latches on receiver battery compartment.
 - Remove battery compartment cover to expose battery connector.
 - Snap batteries into place and position in battery compartment as shown.
- Replace cover and secure latches.

(2) Antenna/Headset Installation

Install receiver antenna and headset as follows:

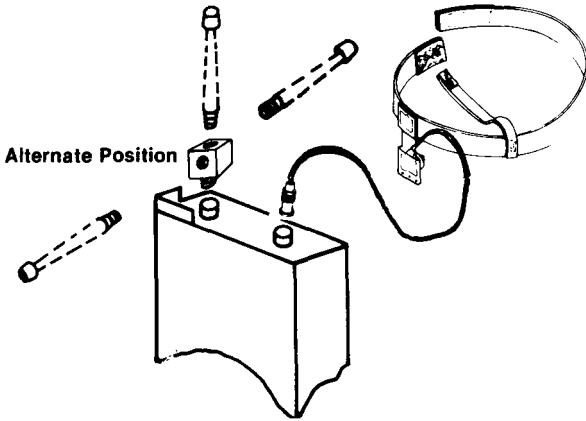

- Install receiver antenna adapter onto ANT socket on front panel. Then connect antenna to adapter.
- Connect headset to PHONE jack.

TM 11-5895-1047-10

b) Detector Preparation (RF MODE)

(1) Battery Installation

Detector DT-577(V)/TRS-2(V) requires one battery for operation. Install battery as follows:

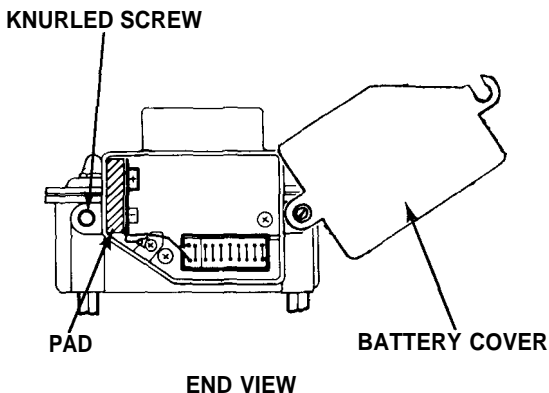

- Set RF-OFF-W switch to OFF.
- Loosen knurled screws to release battery cover.
- Snap battery into clip and place in compartment with connector against pad.
- Note area code and detector ID on inside of battery compartment cover. List on receiver writing surface.
- Close battery compartment and tighten knurled screws.

(2) Antenna Installation

Install detector antenna as follows (RF Mode only):

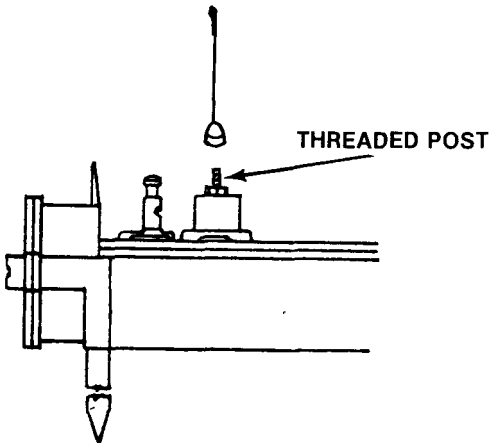

- Screw detector antenna onto threaded post top of detector.

(3) Stake Installation

To be installed at time of deployment/use.
Screw holding stakes into bottom of detector.

TM 11-5895-1047-10

c) Receiver Preparation (WIRE MODE)

(1) Battery Installation

Receiver R-1808)/TRS-2 requires two batteries for operation. Batteries are installed as follows:

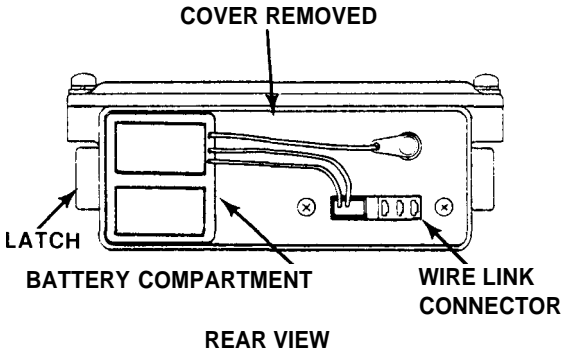

- Set DSPL-TONE-OFF Switch to OFF.
- Release latches on receiver battery compartment.
- Remove battery compartment cover to expose battery connector.
- Snap batteries into place and position in battery compartment as shown.

(2) Wire Link Installation.

Connect wire link to receiver base as shown below.

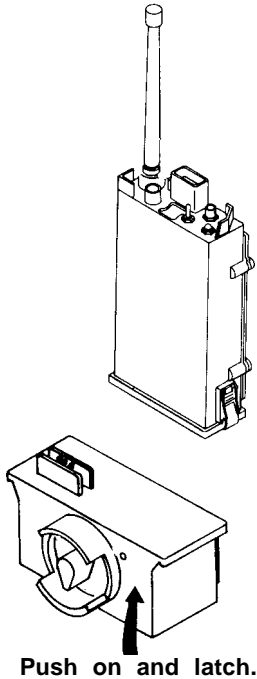

2-7. INITIAL/PREMISSION CHECKS

a) Receiver Check

After installation of batteries and antenna, the PEWS receiver should be checked for proper operation.

NOTE

Procedure is for one receiver, repeat all steps for second receiver check.

- (1) Set DSPL-TONE-OFF Switch to TONE position. Listen for tone in headset. If no tone is heard refer to troubleshooting section for corrective procedure.

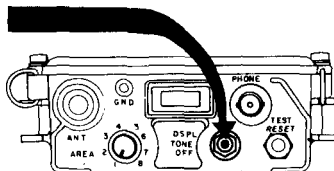

- (2) Set DSPL-TONE-OFF switch to OFF position.
- (3) Set DSPL-TONE-OFF switch to DSPL position.

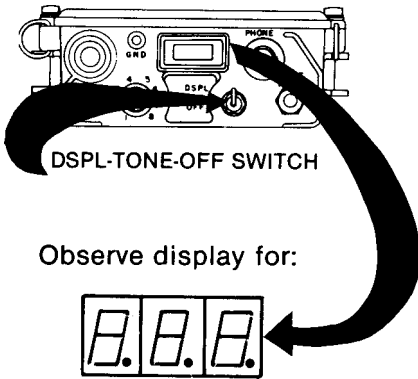

1. "L"
2. 8. 8. 8. Alternates with "L"
3. Clears

NOTE

If an "L" remains batteries are low and should be replaced.

TM 11-5895-1047-10

- (4) Press and hold TEST-RESET button and observe for this display.

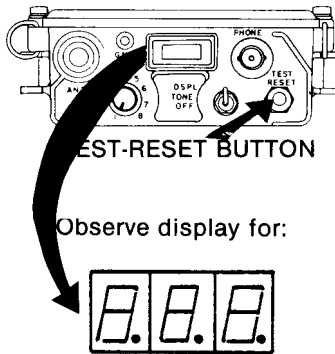

b) Detector Check

NOTE

The following steps require a working receiver.

- (1) Set the receiver to DSPL.
- (2) Set the receiver AREA switch to the same area number as the detector under test.

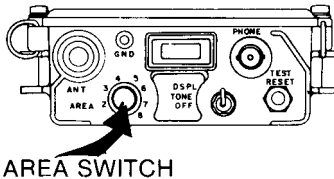

- (3) Check all detectors for RF Mode of operation as follows:

NOTE

Procedure is for one detector. Repeat all steps for each detector.

- (a) Test the detector for operation by placing power switch to RF and press and release TEST button. Observe receiver display for response.

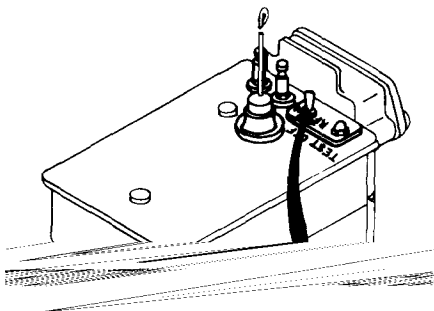

TM 11-5895-1047-10

Receiver display must indicate:

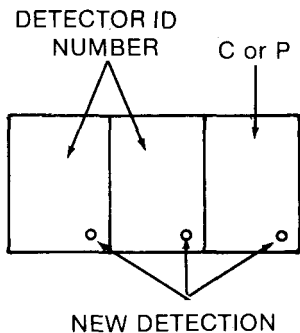

- (b) If detector does not operate correctly; refer to troubleshooting section for corrective procedure.

c) Wire Link Check.

NOTE

Procedure is for one wire link. Repeat all steps for the 2nd wire.

- (1) Connect wire link to an operating receiver.

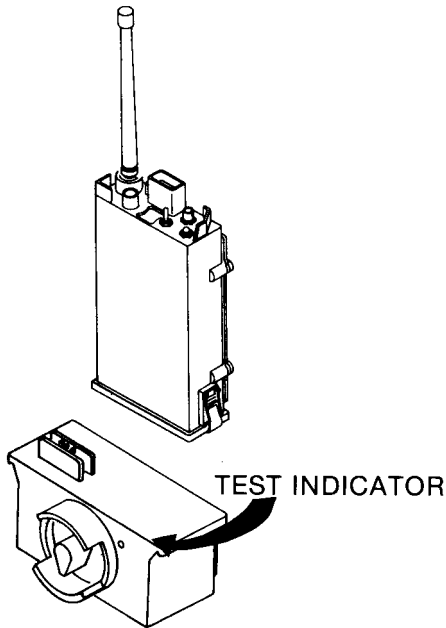

- (2) Set TEST switch through positions 1 thru 9 and observe flashing indicator.

TM 11-5895-1047-10

- (3) Connect a working detector to the wire link using a short length of field wire.

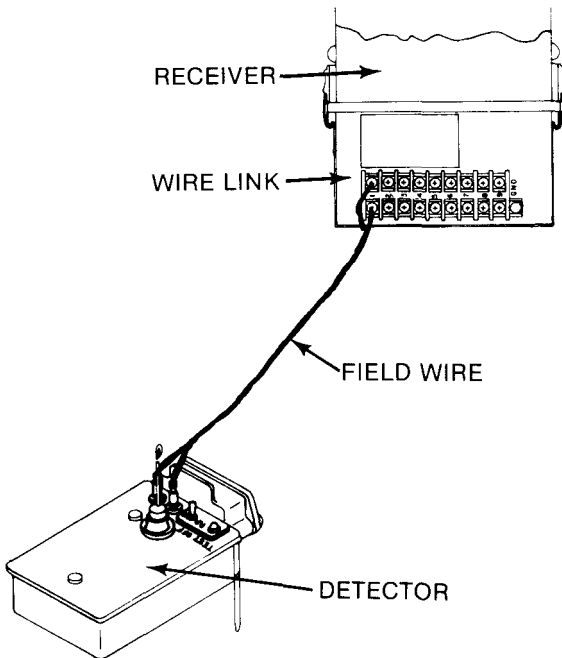

- (4) Set TEST switch to REC position.
- (5) Set detector power switch to "W" press and release the test button while observing receiver display.

Receiver display must indicate:

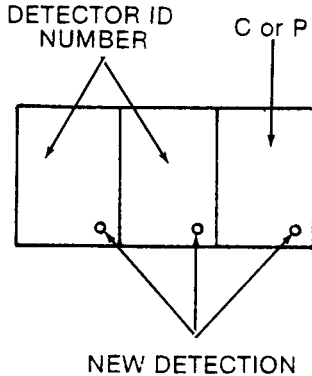

- (6) Remove field wire from detector and wire link.
- (7) Remove wire link and replace cover on receiver.

TM 11-5895-1047-10

d) Receiver Memory Check.

Connect two (2) working detectors to the Receiver by RF Mode or Wire mode or a combination of both.

(1) Set DSPL-TONE-OFF switch to DSPL and press and release TEST button on both detectors (not at the same time).

(2) Observe display for approximately 30 seconds. During this time the detector numbers from the 2 test detectors should appear alternately in the display.

(3) Press TEST/RESET button on receiver while observing display. Display should blank out.

2-8. SYSTEM PLANNING AND INSTALLATION

- a) Installation Planning
 - (1) System Planning

The PEWS will be installed in accordance with particular security requirements of a site.

Site Considerations:

- Size of area to be protected (How many detectors you will need).
- Type of terrain.
- Type of soil in area.
- Noise level in area.
- Tactical considerations (whether there are paths or roads to be monitored, location of camp site etc.).

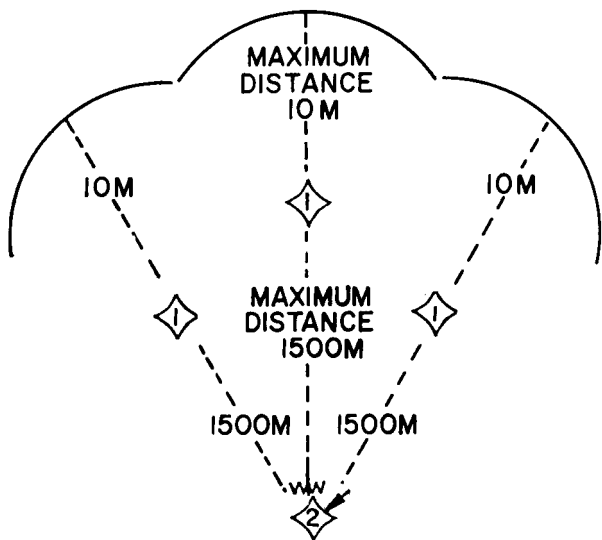

1 DETECTOR POSITION

2 RECEIVER POSITION

TYPICAL PEWS CAPABILITY

- Size of area.

Maximum detection range of each detector is a 10 meter radius.

Maximum distance from Detector to Receiver is 1500 meters.

(2) Transmission Path Planning

Effective operating ranges will be less if there is not a CLEAR PATH between the detector and receiver (RF mode).

Terrain should be level as possible or receiver should be elevated above detectors (RF mode).

FIELD WIRE should be laid where it will not be damaged by rocks or other hazards (Wire Mode).

FIELD WIRE should be camouflaged as much as possible.

(3) Detector Site and Layout

PEWS will be used to provide early warning to riflemen and weapons positions.

Areas where there is no Clear Path should be noted. These are areas where trees, rocks, hills, etc. block your view. In general, detectors should be installed in areas where you cannot see enemy approaching.

TM 11-5895-1047-10

b) Installation of Detectors

After choosing detector sites, install assembled detectors.

- Dig shallow hole at detector location about one inch deep, slightly larger than detector.
- Ž Sketch out the location and ID numbers of each detector you install to be sure that you have fully covered area to be protected. You may sketch on the writing area located on the receiver.

NOTE

When emplacing detector, observe arrow and note on detector case. When detecting vehicles, the detector must be aligned so that arrow is parallel to expected travel of vehicles.

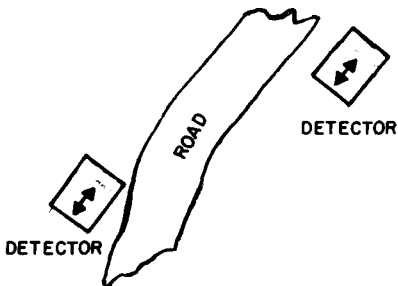

- Ž Push detector into hole so that holding stakes are firmly implanted into ground. DO NOT STEP ON DETECTOR.

TM 11-5895-1047-10

- Pack soil firmly against sides of detector case. Do not cover top of detector case.
- If detector is to be used in wire mode, strip insulation from ends of field wire with wire cutters.

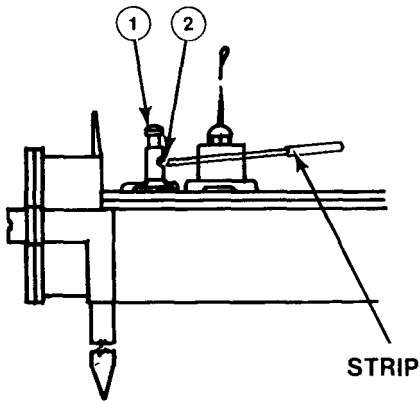

- Insert each wire end into terminal posts on detector by pressing down top of post (1) inserting wire into post (2)
- Ž Run field wire to receiver location; camouflage as necessary.

TM 11-5895-1047-10

NOTE

Detector antennas are NOT required for wire mode of operation. Do NOT allow any plants or other objects to touch detector antenna or data post.

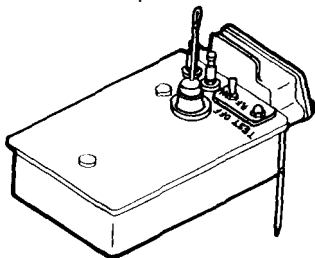

- Turn detector on - set RF-OFF-W switch to RF (for radio mode) or W (for wire mode).
- Camouflage detector as necessary.
- Repeat the above steps for installation of other detectors.

c) Optional Use of Detectors in Wire Mode.

For quick set-up of detectors, or special tactical situations, detectors may be set-up so that only one field wire pair is required to connect several detectors. This is called Hot-Loop.

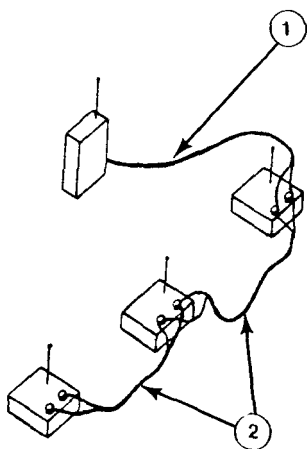

- 1 Field wire ① is run to first detector in Hot-Loop group. Other lengths of field wire ② connect other detectors with each other in "Parallel".

TM 11-5895-1047-10

d) Installation of Receiver

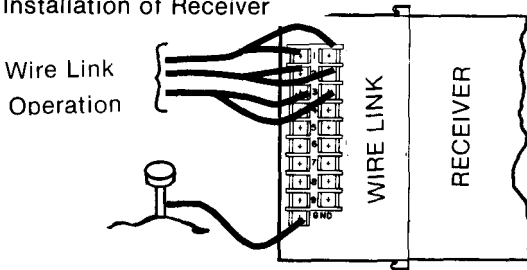

- Attach wire link to receiver.
- Strip ends of field wire pairs from detectors.
- Using screwdriver, connect one pair of wires from each detector to numbered terminal on wire link (installed on receiver).
- Using screwdriver, connect wire lead from ground rod to GND terminal on wire link.
- Push ground rod into soil in area where receiver is to remain operating.

CAUTION

Grounding rod should always be connected to the wire link during operation to prevent electrical shock.

2-9. OPERATING PROCEDURE

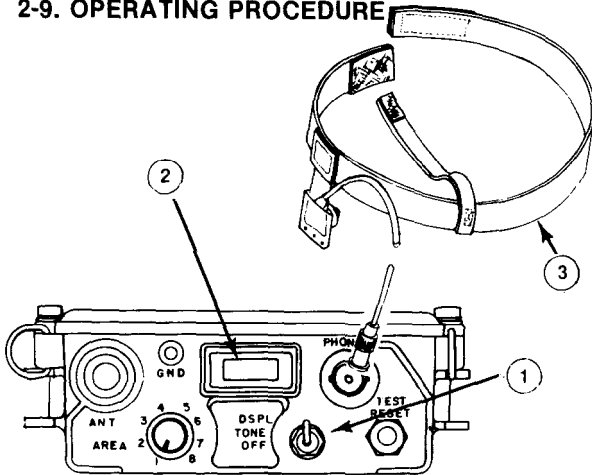

- To operate PEWS, set DPSL-TONE-OFF switch (1) to either the DPSL or TONE position.
- When intruder is detected the display window (2) will indicate alarm in the DPSL position. In addition a tone will be heard in the headset.
- For tone operation only, set the switch to the TONE position. When an intruder is detected tone will be heard in headset (3).

NOTE

Use TONE position to conserve battery during long periods of monitoring.

If battery is low, an "L" will be displayed in display window even if TONE position is selected.

TM 11-5895-1047-10

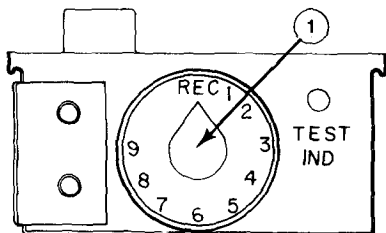

ŽWhen in wire mode be sure
REC-TEST switch on wire link
is set to REC position.

ŽSet AREA switch to detector area (assigned to
each detector) you want to monitor.

Check your sketch on writing surface
of receiver to determine proper AREA
number of detector.

- Detecting an intruder (DSPL position).
 1. When receiver is first turned on,
an 8. 8. 8. will appear in display window
and tone will sound for about ten seconds.

2. Display should then clear.

You can check receiver for proper display or low battery at any time during operation by using TEST RESET button. Press button in and hold;

8.	8.	8.
----	----	----

 should always appear in display window.

3. When detector senses intruder, message is sent to receiver.

Detector ID number appears on receiver display.

Intruder classification displays (P = personnel, C = vehicle).

Decimal points will always light when a new intrusion is displayed.

1.	0.	P.
----	----	----

Tone will sound in headset.

4. Information is stored in receiver memory.

When new messages from other detectors are received, they will be momentarily displayed on receiver with decimal points and tone.

When no new messages are being received, previously received (old) messages (without decimal points) are repeated in display window in rotation (starting with lowest number).

6	P
---	---

1	0	P
---	---	---

1	3	P
---	---	---

TM 11-5895-1047-10

If both personnel and vehicle intrusions are detected, they will both be displayed and repeated in rotation, starting with the lowest detector ID number.

6 P 6 C 1 O P 1 O C

Turning DSPL-TONE-OFF switch (1) to TONE will make display go blank, but will not erase receiver memory.

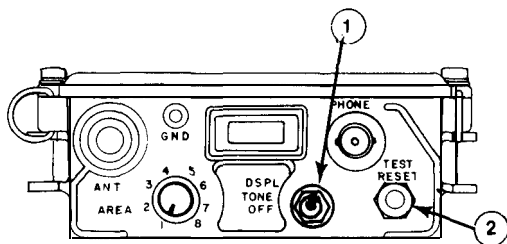

To erase memory, press TEST RESET button (2) on receiver.

5. If you see the same ID numbers (with decimals and audio alert) displayed more than once, there may be more than one intruder near detector.

TM 11-5895-1047-10

- Detecting an intruder (TONE position).
Operation in TONE position is the same as in DSPL position, except that no display will appear in WINDOW.

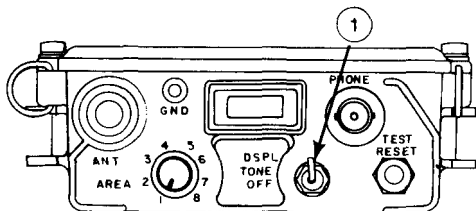

If tone is heard in headset while monitoring for intruder, turn DSPL-TONE-OFF switch to DSPL position.

ID number and classification of intruder will appear on display.

Any messages stored in receiver memory will be displayed in rotation.

Switching from DSPL to TONE or TONE to DSPL will not erase receiver memory.

NOTE

When detectors are reporting at a high rate (many intruders), there is a greater chance of false alarm messages.

TM 11-5895-1047-10

- Detector identification.

After you have noted the ID number(s) of detector(s) that is reporting, refer to your deployment sketch to find area and location of detector.

Using your deployment sketch, it may be possible to determine movements of a large number of intruders by noting which detectors are reporting.

- System shut down.

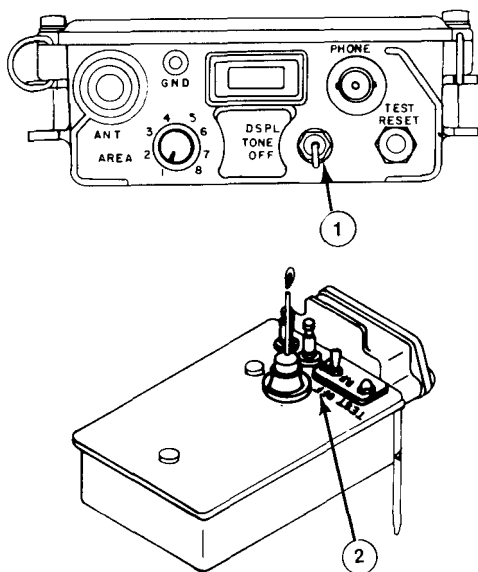

- ① Set receiver DSPL-TONE-OFF switch to OFF position.
- ② If the tactical situation permits, turn Detector RF-OFF-W switches to the OFF position.

2-10. PREPARATION FOR MOVEMENT

When leaving a site, disassemble system as follows:

a. Detectors.

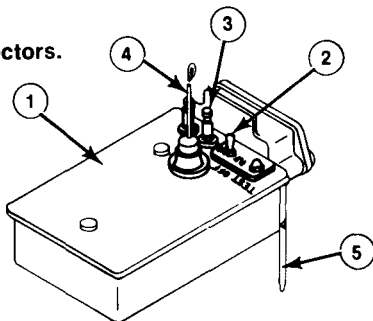

NOTE

Retrieve detectors only if authorized to do so.

- ① Pickup detectors from their positions.
- ② Turn RF-OFF-W switch to OFF position.
- ③ Disconnect field wire from terminals (if in wire mode).
- ④ Unscrew antennas from top of detectors (if in RF mode).
- ⑤ Unscrew holding stakes from bottom of detectors.

Wipe any dirt from components with cloth.
Store components in bag.

b. Wire Link

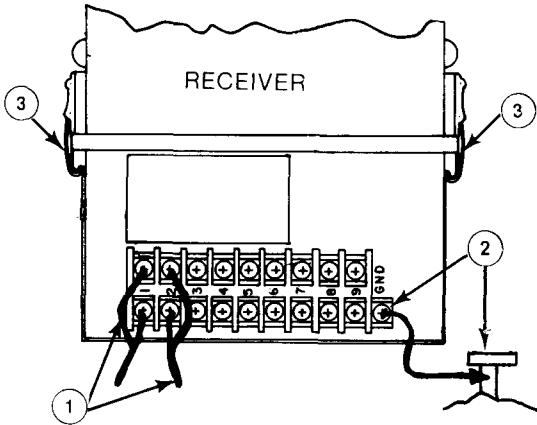

- ① Disconnect field wire pairs from terminals with screwdriver.
- ② Disconnect ground rod lead from wire link and store in center pocket of bag.
- ③ Unlatch wire link from receiver and store in bag.
- ④ Replace battery compartment cover on receiver.

TM 11-5895-1047-10

c. Receiver

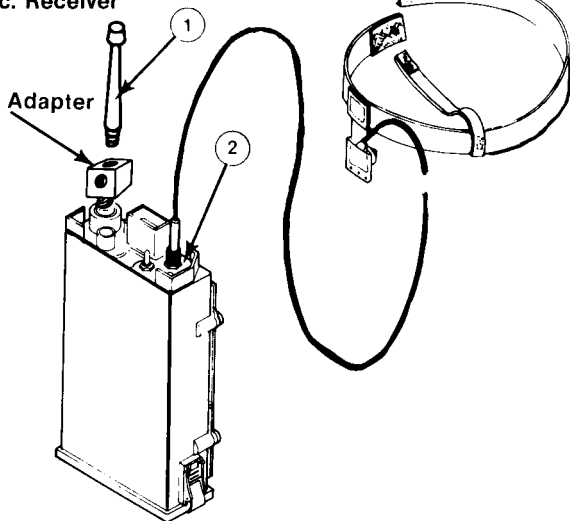

- ① Unscrew antenna from adapter and store in bag.
- ② Disconnect headset from connector arm store in bag.
- ③ Place receiver in bag.

Make sure all components of the PEWS are accounted for. Refer to the Components of End Item List (appx B) and check system for completeness.

**Section IV. OPERATION UNDER UNUSUAL
CONDITIONS**

2-11. OPERATION IN UNUSUAL WEATHER

The AN/TRS-2(V) is fully sealed and weather protected for operation in hot, cold, damp or moderate climates. However under extreme conditions, the following conditions may exist:

a. Extreme Cold Climate. Extreme cold causes field wire to become hard, brittle, and difficult to handle. Binding posts and connectors are subject to damage from hard ground and icing conditions.

b. Hot Climates. In hot dry climates, connectors and binding posts are subject to damage from dust and sand.

c. Warm Damp Climates. In warm damp climates, the equipment is subject to damage from moisture and fungi.

d. Cold Damp Climates. In cold damp climates the equipment is subject to damage from moisture.

2-12. PRECAUTIONS TC FOLLOW

- For cold weather operation use Battery BA-3090 in lieu of BA-90.
- Make sure that binding posts, connectors, headset and antennas are free of ice, snow, dust, or sand.
- Be sure the receiver and detector battery covers are in place.
- Never drag or place loose end of headset cable in the snow drift, sand or hard ground.
- Be sure to remove dirt, moisture, and fungi from equipment.

CHAPTER 3. MAINTENANCE INSTRUCTIONS

3-1. LUBRICATION INSTRUCTIONS

The PEWS does not require lubrication.

3-2. TROUBLESHOOTING PROCEDURES

Troubleshoot the PEWS using these procedures as your guide.

- a. These are the common malfunctions which you may find during the operation or maintenance of the PEWS or its components. You should perform the tests/inspections and corrective actions in the order listed.
- b. This manual cannot list all malfunctions that may occur, nor all tests or inspections and corrective actions. If a malfunction is not listed or is not corrected by listed corrective actions, notify your supervisor.

TROUBLESHOOTING GUIDE

MALFUNCTION	TEST OR INSPECTION	CORRECTIVE ACTION
-------------	--------------------	-------------------

RECEIVER

1. NO DISPLAY OR TONE OBTAINED DURING OPERATION

TM 11-5895-1047-10

TROUBLESHOOTING RECEIVER

(Continued)

Step 1. Check to see that batteries are good.

Replace batteries and re-check operation,

Step 2. Check that DSPL-TONE-OFF switch is in DSPL or TONE position.

Set switch to DSPL or TONE position

Step 3. Check that AREA switch is in the correct position.

Set AREA switch to correct position. If above steps fail, replace receiver.

**2. NO DISPLAY OBTAINED DURING OPERATION
(TONE HEARD)**

Step 1. Check to see that batteries are good.

Replace batteries and re-check operation.

3. NO TONE HEARD IN HEADSET (DISPLAY O. K.)

Step 1. Check to see that headset plug is properly connected to receiver.

Tighten headset connector.

**TROUBLESHOOTING RECEIVER
(Continued)**

Step 2. Check that headset is operative. Plug headset to other receiver. Turn DSPL-TONE-OFF switch to DSPL position and press TEST RESET button. Tone should be heard.

If no tone is heard, replace headset.

4. "L" APPEARS ON RECEIVER DISPLAY

Step 1. Check condition of batteries.

Replace batteries and re-check operation.

5. NO RF OPERATION

Step 1. Check that antenna is connected properly. Insure that connector or antenna adapter is not corroded or dirty.

Replace antenna or adapter if necessary.

Step 2. Check that radio paths are not heir blocked by hills, metallic objects, or other sour of interference.

Move receiver to minimize blockage.

TM 11-5895-1047-10

TROUBLESHOOTING RECEIVER

(Continued)

6. NO WIRE LINK OPERATION

Step 1. Check that wire link is securely installed on receiver.

Disconnect and reinstall wire link.

Step 2. Check that field wires are connected properly to terminals on wire link and are not shorted or broken.

Replace or splice wire.

If any of the above steps fail to correct receiver malfunction, replace receiver.

TROUBLESHOOTING DETECTOR

1. DETECTOR INOPERATIVE (WIRE AND RF MODE)

Step 1. Check that RF-OFF-W switch is set to RF or W position.

Set switch to RF or W Position.

Step 2. Check to see that detector batteries are good.

Re-check operation using TEST button.

Step 3. Check that detector code plug is installed firmly in its socket.

Push code plug into socket gently.

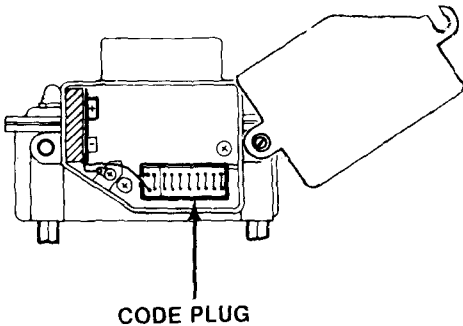

TM 11-5895-1047-10

TROUBLESHOOTING DETECTOR

(Continued)

Step 4. If using detector in wire mode, insure that field wires connected to detector are secure (not broken or shorted).

Fix connections as necessary.

If above steps fail to correct detector malfunction, replace detector.

Step 5. If using detector in RF mode, insure that antenna is connected to post and antenna is not touching any external objects.

Tighten antenna and/or clear external objects.

WIRE LINK

1. WIRE LINK INOPERABLE (NO OPERATION IN WIRE MODE, RECEIVER BATTERIES O. K.)

Step 1. Check that wire link is securely fastened to receiver.

Secure wire link properly.

Step 2. Insure that REC-TEST switch is set to REC position.

Set switch to REC position,

If above steps fail to correct wire link malfunctions, replace wire link.

3-3. CLEANING

- a. Receiver. Receiver should be cleaned whenever necessary using clean, dry, lint-free cloth. You may use small amounts of water if necessary.
- b. Detectors and holding stakes. Detectors and holding stakes should be cleaned with cloth after operation. Wipe any dirt from surfaces before placing components back in bag.
- c. Wire link. Clean wire link with cloth as necessary. Insure that no terminal screws are missing.
- d. Ground rod. Clean ground rod with cloth as necessary. Be certain that wire lead and terminal are not damaged.

**APPENDIX A
REFERENCES**

The following is a list of applicable references that are available to the operator of the Pews.

AR 385-40	Accident Reporting and Records
DA Pam 310-4	Index of Technical Manuals, Technical Bulletins, Supply Manuals (Types 7, 8, and 9), Fabrication Orders
DA Pam 310-7	U.S. Army Equipment Index of Modification Work Orders
TM 38-750	The Army Maintenance Management System (TAMMS)

APPENDIX B
COMPONENTS OF END ITEM AND BASIC
ISSUE ITEMS LISTS
Section L INTRODUCTION

1. Scope

This appendix lists integral components of and basic issue items for the PEWS to help you inventory items required for safe and efficient operation.

2. General

The Components of End Item and Basic Issue Items Lists are divided into the following sections:

a. Section II. Components of the End Item. This listing is for informational purposes only, and is not authority to requisition replacements. These items are part of the end item, but are removed and separately packaged for transportation or shipment. As part of the end item, these items must be with the end item whenever it is issued or transferred between property accounts. Illustrations are furnished to assist you in identifying the items.

b. Section III. Basic Issue Items. These are the minimum essential items required to place the PEWS in operation, to operate it, and to perform emergency repairs. Although shipped separately packaged BII must be with the PEWS during operation and whenever it is transferred between property accounts. The illustrations will assist you with hard-to-identify items. This manual is your authority to request/requisition replacement BII, based on TOE/MTOE authorization of the end item.

B-3. Explanation of Columns

The following provides an explanation of columns found in the tabular listings:

a. Column (1) - Illustration Number (Illus Number).

This column indicates the number of the illustration in which the item is shown.

b. Column (2) - National Stock Number. Indicates the National stock number assigned to the item and will be used for requisitioning purposes.

c. Column (3) - Description. Indicates the National item name and, if required, a minimum description to identify and locate the item. The last line for each item indicates the FSCM (in parentheses) followed by the part number. If item needed differs for different models of this equipment, the model is shown under the "Usable On" heading in this column. These codes are identified as:

Code	Used On
DTJ	AN/TRS-2(v)1
DZ3	AN/TRS-2(v)2
DZ4	AN/TRS-2(V)3
DZ5	AN/TRS-2(V)4
DZ6	AN/TRS-2(V)5
DZ7	AN/TRS-2(V)6

3. Explanation of Columns (Cont.)

d. Column (4) - Unit of Measure (U/M). (4) Indicates the measure used in performing the actual operational/maintenance function. This measure is expressed by a two-character alphabetical abbreviation (e.g., ea., in., pr.).

e. Column (5) - Quantity required (Qty rqr). (5) Indicates the quantity of the item authorized to be used with/on the equipment.

B-4

Section II. COMPONENTS OF END ITEM

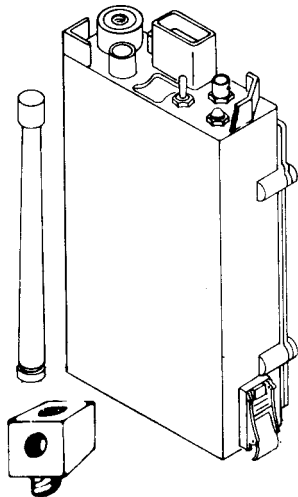

1

(Includes headset,
antenna, and
antenna adapter)

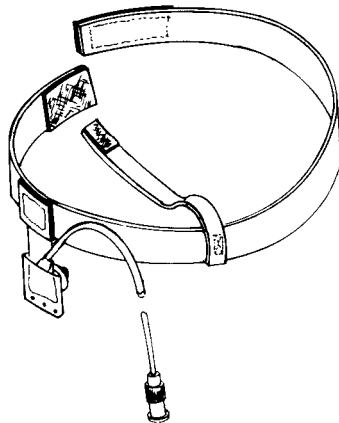

TM 11-5895-1047-10

(1) ILLUS NO.	(2) NATIONAL STOCK NUMBER	(3) DESCRIPTION (FSCM) AND PART NUMBER USABLE ON CODE	(4) U/M	(5) QTY REQD
		Receiver, Radio (80058)-R-1808(V)/ TRS-2(V)	EA	2
	5895-01-068-6854	R-1808(V)1/TRS-2(V)		
	5895-01-068-8577	R-1808(V)2/TRS-2(V)	DTJ	
	5895-01-068-8578	R-1808(V)3/TRS-2(V)	DZ3	
	5895-01-068-6855	R-1808(V)4/TRS-2(V)	DZ4	
	5895-01-080-1657	R-1808(V)5/TRS-2(V)	DZ5	
	5895-01-064-2734	R-1808(V)6/TRS-2(V)	DZ6	
			DZ7	

Section II. COMPONENTS OF END ITEM

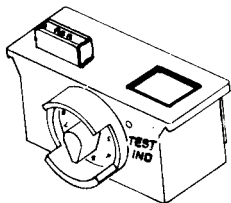

2

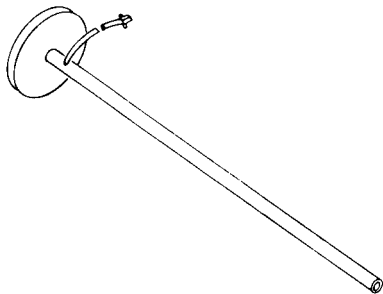

3

(1) ILLUS NO.	(2) NATIONAL STOCK NUMBER	(3) DESCRIPTION (FSCM) AND PART NUMBER	(4) U/M	(5) QTY RFQD
2	5895-01-075-0071	Sensor, Interface, Wire Link (80058)-MX-9738/TRS-2(V) DTJ DZ3 DZ4 DZ5 DZ6 DZ7	EA	2
3	5975-01-079-7927	Grounding Rod (56977)-CJ001323 DTJ DZ3 DZ4 DZ5 DZ6 DZ7	EA	2

B-7

TM 11-5895-1047-10

Section II. COMPONENTS OF END ITEM

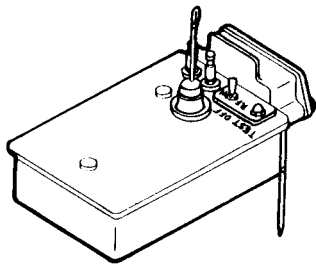

4

(Includes antenna
and two (2)
holding stakes)

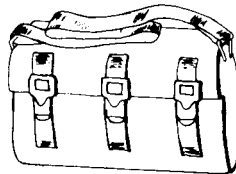

5

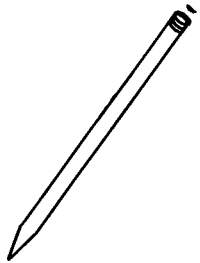

7



6

Section III. BASIC ISSUE ITEMS

(1) ILLUS NO.	(2) NATIONAL STOCK NUMBER	(3) DESCRIPTION (FSCM) AND PART NUMBER	(4) U/M	(5) QTY REQD
6	5895-01-085-1538	Antenna, Detector (56977)-SM-C-783413 DTJ DZ3 DZ4 DZ5 DZ6 DZ7	EA	3
7		Stake, Holding (56977)-SM-C-783217 DTJ DZ3 DZ4 DZ5 DZ6 DZ7	EA	4

B-11/B-12 blank

TM 11-5895-1047-10

APPENDIX C
ADDITIONAL AUTHORIZATION LIST
Section I. INTRODUCTION

1. Scope

This appendix lists additional items you are authorized for the support of the PEWS.

2. General

This list identifies items that do not have to accompany the PEWS and that do not have to be turned in with it. These items are all authorized to you by CTA, MTOE, TDA, or JTA.

3. Explanation of Listing

National stock numbers, descriptions, and quantities are provided to help you identify and request the additional items you require to support this equipment. The items are listed in alphabetical sequence by item name under type document (i.e., MTOE) which authorizes the item to you.

Section II. ADDITIONAL AUTHORIZATION LIST

NATIONAL STOCK NUMBER	DESCRIPTION (FSCM) AND PART NUMBER	U/M USABLE ON CODE	QTY REQD
6135-00-850-3177	MTOE AUTHORIZED ITEMS Battery, Dry (80058) BA-90 Battery, Dry (cold weather) (80058) BA-3090	EA EA	3 3
5180-00-408-1859	Tool Kit (80058) TE 33	EA	1
3895-00-089-7279	Dispenser, Cable (1/4 mile) (80058) MX-6895-()TT	EA	1
3895-00-039-7278	Dispenser, Cable (1/2 mile) (80058) MX-6894()-TT	EA	1

APPENDIX D
EXPENDABLE SUPPLIES & MATERIALS LIST
Section I. INTRODUCTION

1. Scope

This appendix lists expendable supplies and materials you will need to operate and maintain the PEWS. These items are authorized to you by CTA 50-970, Expendable Items (Except Medical, Class V, Repair Parts, and Heraldic Items).

2. Explanation of Columns

a. Column (1) - Item number. This number is assigned to the entry in the listing and is referenced in the narrative instructions to identify the material (e.g., "Use cleaning compound, item 5, App. D").

b. Column (2) - Level. This column identifies the lowest level of maintenance that requires the listed item.

C - Operator/Crew

c. Column (3) - National Stock Number. This is the National stock number assigned to the item, use it to request or requisition the item.

2. Explanation of Columns (Cont.)

d. Column (4) - Description. Indicates the Federal item name and, if required, a description to identify the item. The last line for each item indicates Federal Supply Code for Manufacturer (FSCM) in parentheses, followed by the part number.

e. Column (5) - Unit of Measure (U/M). Indicates the measure used in performing the actual maintenance function. This measure is expressed by a two-character alphabetical abbreviation (e.g., ea., in., pr.). If the unit of measure differs from the unit of issue, requisition the lowest unit of issue that will satisfy your requirements.

Section II. EXPENDABLE SUPPLIES AND MATERIALS LIST

(1) ITEM NUMBER	(2) LEVEL	(3) NATIONAL STOCK NUMBER	(4) DESCRIPTION	(5) UIC
1	C	8305-00-267- 3015	Cloth, Lint Free	YD

TM 11-5895-1047-10

By Order of the Secretary of the Army:

EDWARD C. MEYER
General, United States Army
Chief of Staff

Official:

J.C. PENNINGTON

Major General, United States Army

> The Adjutant General

TM 11-5895-1047-10

DISTRIBUTION:

Active Army

▶ HISA (Ft Monmouth) (21)	USAES (2)
USAINSCOM (2)	USAIGS (3)
COE (1)	MAAG (1)
TSG (1)	USARMIS (1)
USAARENBD (1)	USAERDAA (1)
DARCOM (1)	USAERDAW(1)
TRADOC (2)	Ft Gordon (10)
OS Maj Cnd (4)	Ft Carson (5)
TECOM (2)	Army Dep (1) except
USACC (4)	SAAD (30)
MDW (1)	TOAD (14)
Armies (2)	SHAD (2)
Corps (2)	Ft Gillem (10)
Svc Colleges (1)	USA Dep (1)
USASIGS (5)	Sig Sec USA Dep (1)
USAADS (2)	Ft Richardson (CERCOM Ofc)(2)
USAFAS (2)	Units org under fol TOE:
USAARMS (2)	29-207 (2)
USAIS (2)	29-610 (2)

NG: None

USAR: None

For explanation of abbreviation used, see AR 310-50.

RECOMMENDED CHANGES TO EQUIPMENT TECHNICAL PUBLICATIONS



THEN...JOT DOWN THE
DOPE ABOUT IT ON THIS FORM.
CAREFULLY TEAR IT OUT, FOLD IT
AND DROP IT IN THE MAIL.

SOMETHING WRONG WITH PUBLICATION

FROM: (PRINT YOUR UNIT'S COMPLETE ADDRESS)

DATE SENT

PUBLICATION NUMBER

PUBLICATION DATE

PUBLICATION TITLE

BE EXACT PIN-POINT WHERE IT IS

PAGE
NO.

PARA-
GRAPH

FIGURE
NO.

TABLE
NO.

IN THIS SPACE, TELL WHAT IS WRONG
AND WHAT SHOULD BE DONE ABOUT IT.

TEAR ALONG PERFORATED LINE

PRINTED NAME, GRADE OR TITLE AND TELEPHONE NUMBER

SIGN HERE

The Metric System and Equivalents

Linear Measure

1 centimeter = 10 millimeters = .39 inch
 1 decimeter = 10 centimeters = 3.94 inches
 1 meter = 10 decimeters = 39.37 inches
 1 dekameter = 10 meters = 32.8 feet
 1 hectometer = 10 dekameters = 328.08 feet
 1 kilometer = 10 hectometers = 3,280.8 feet

Weights

1 centigram = 10 milligrams = .15 grain
 1 decigram = 10 centigrams = 1.54 grains
 1 gram = 10 decigrams = .035 ounce
 1 dekagram = 10 grams = .35 ounce
 1 hectogram = 10 dekagrams = 3.52 ounces
 1 kilogram = 10 hectograms = 2.2 pounds
 1 quintal = 100 kilograms = 220.46 pounds
 1 metric ton = 10 quintals = 1.1 short tons

Liquid Measure

1 centiliter = 10 milliliters = .34 fl. ounce
 1 deciliter = 10 centiliters = 3.38 fl. ounces
 1 liter = 10 deciliters = 33.81 fl. ounces
 1 dekaliter = 10 liters = 2.64 gallons
 1 hectoliter = 10 dekaliters = 26.42 gallons
 1 kiloliter = 10 hectoliters = 264.18 gallons

Square Measure

1 sq. centimeter = 100 sq. millimeters = .155 sq. inch
 1 sq. decimeter = 100 sq. centimeters = 15.5 sq. inches
 1 sq. meter (centare) = 100 sq. decimeters = 10.76 sq. feet
 1 sq. dekameter (are) = 100 sq. meters = 1,076.4 sq. feet
 1 sq. hectometer (hectare) = 100 sq. dekameters = 2.47 acres
 1 sq. kilometer = 100 sq. hectometers = .386 sq. mile

Cubic Measure

1 cu. centimeter = 1000 cu. millimeters = .06 cu. inch
 1 cu. decimeter = 1000 cu. centimeters = 61.02 cu. inches
 1 cu. meter = 1000 cu. decimeters = 35.31 cu. feet

Approximate Conversion Factors

To change	To	Multiply by	To change	To	Multiply by
inches	centimeters	2.540	ounce-inches	newton-meters	.007062
feet	meters	.305	centimeters	inches	.394
yards	meters	.914	meters	feet	3.280
miles	kilometers	1.609	meters	yards	1.094
square inches	square centimeters	6.451	kilometers	miles	.621
square feet	square meters	.093	square centimeters	square inches	.155
square yards	square meters	.836	square meters	square feet	10.764
square miles	square kilometers	2.590	square meters	square yards	1.196
acres	square hectometers	.405	square kilometers	square miles	.386
cubic feet	cubic meters	.028	square hectometers	acres	2.471
cubic yards	cubic meters	.765	cubic meters	cubic feet	35.315
fluid ounces	milliliters	29.573	cubic meters	cubic yards	1.308
pints	liters	.473	milliliters	fluid ounces	.034
quarts	liters	.946	liters	pints	2.113
gallons	liters	3.785	liters	quarts	1.057
ounces	grams	28.349	liters	gallons	.264
pounds	kilograms	.454	grams	ounces	.035
short tons	metric tons	.907	kilograms	pounds	2.205
pound-feet	newton-meters	1.356	metric tons	short tons	1.102
pound-inches	newton-meters	.11296			

Temperature (Exact)

°F	Fahrenheit	5/9 (after	Celsius	°C
	temperature	subtracting 32)	temperature	

PIN: 046585-002